



Table of Contents

1	Installation	3
1.1	Mechanical Installation	3
1.1.1	Support Interface (Support Surface)	3
1.1.2	Weighing Interface (Weighing Platform)	4
1.2	Electrical Installation	5
1.2.1	Typical Configuration	5
1.2.2	Pin Assignment of the M12-4 Connector	5
1.2.3	Power supply	6
1.2.4	Cables and Wiring	6
1.2.5	Status LEDs and Reed Switch	7
2	Configuration	11
2.1	Industrial Ethernet	11
2.2	Ethernet TCP/IP	11
3	Operation	12
3.1	Operation Limits	12
3.2	Applying / Removing the Weighing Object	13
3.3	Air connections	14
4	Calibration and Adjustment	15
5	Technical Data	16
5.1	General Data	16
5.2	Type Designation Code	17
5.3	Interface Specifications	17
5.4	Dimensions	18
6	Accessories and Spare Parts	19
6.1	Accessories	19
6.2	Spare Parts	20

1 Installation

1.1 Mechanical Installation

1.1.1 Support Interface (Support Surface)

Observe the following when designing the support interface for the weigh module:

- Wherever possible, provide a vibration-free support surface for the weigh module.
- Determine the floor properties in the location where the system is to be set up.
Make sure that no building oscillations are transferred to the support surface via the floor
- The support surface has to be stiff because a stable mechanical base is mandatory for precise and fast weighing results.
- The support surface must be absolutely level to prevent the weigh module from deformation.
The maximum permissible slope (angle from horizontal) of 0.5 % must not be exceeded.
- The support surface must be cut out according to the template at the connector locations.
- Take care that no vibrations are transmitted via the connecting cable.

Preparing the base plate

- Use the following drilling scheme to prepare the base plate:

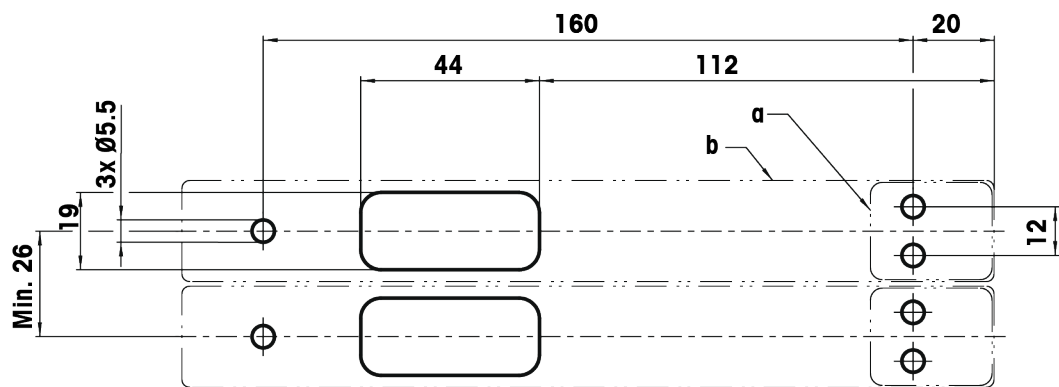

Dimensions in mm

a Weighing pan

b Weighing module

Mounting the weigh module on the support surface

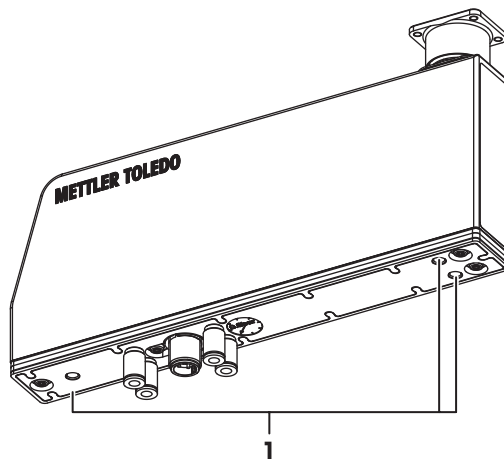

- 1 Make sure that the base plate sealing is properly fixed on the base plate of the weigh module.
- 2 Use the 3 threaded holes (1) (M5, 6 mm deep) at the bottom plate to fasten the weigh module to the support surface.

1.1.2 Weighing Interface (Weighing Platform)

When building a custom weighing platform, the following needs to be considered in order to achieve the best weighing performance.

Material of the Weighing Platform

The material has to be selected from electrically conductive material in order to prevent the accumulation of electrostatic charges.

Weight and stiffness

Light and stiff weighing platforms are less susceptible to vibrations.

Eccentricity

The center of gravity of the custom weighing platform should lie at the center point of the adapter weighing pan.

Mounting the weighing platform

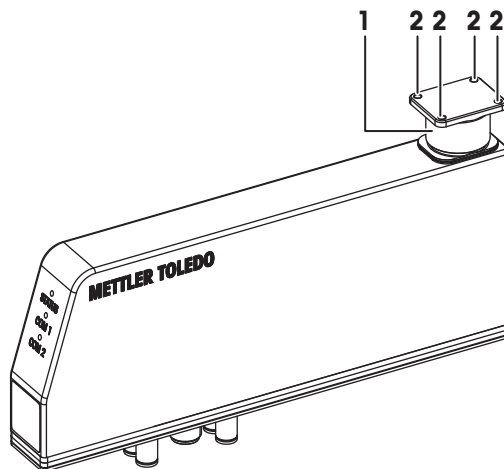

- 1 Take off the adapter weighing pan (1) from the load receiver.
- 2 Use the 4 mounting holes (2) (M3 threaded holes) to fasten the custom weighing platform onto the adapter weighing pan.
- 3 Put the weighing interface consisting of custom weighing platform and adapter weighing pan on the weigh module.

Important

Only mount a custom weighing pan onto the adapter weighing pan when the weighing pan is removed from the weigh module. Otherwise the load cell can be damaged due to overload forces during installation.

1.2 Electrical Installation

1.2.1 Typical Configuration

Multi-line connection

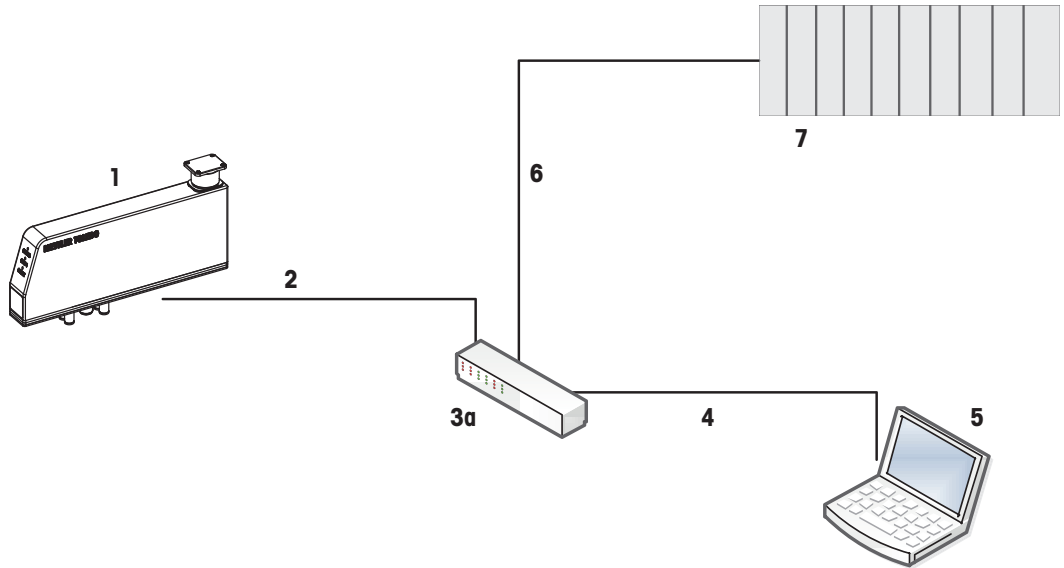

Single-line connection

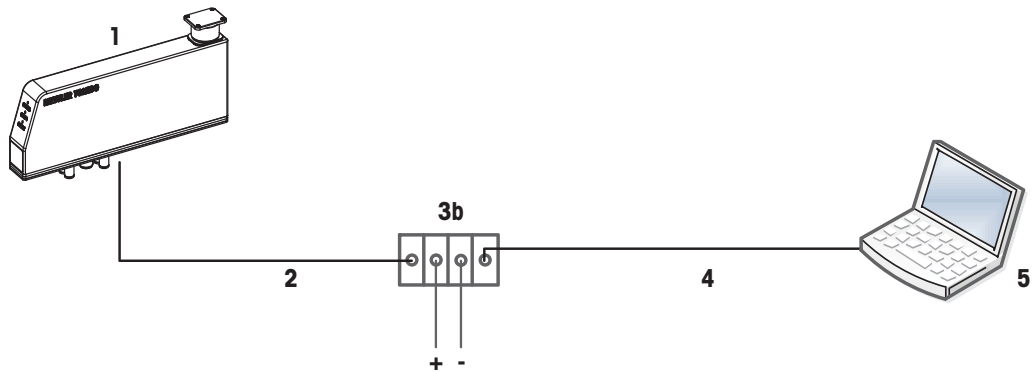

Pos.	Item	Description	Item number
1	WMF weigh module	Various models available	See order information
2	Connection cable	Standard industrial Ethernet cable for PoE, M12-4 position, D-coded, female	3 rd party item
3a	Ethernet switch PoE	For multiple point connection	
3b	Power injector	For single point connection to a PC or laptop	
4	Ethernet cable	To connect to a PC or laptop	
5	PC or laptop	For service and configuration purposes	
6	Ethernet cable	To connect the switch to a PLC	
7	PLC	Control system	

1.2.2 Pin Assignment of the M12-4 Connector

Pin assignment and signal definitions are according to the standard M12-4 (D-coded).

1.2.3 Power supply

The weigh module can be energized with the Power over Ethernet (PoE).

- Power over Ethernet (PoE)
- Mode A (end span)
- Class 1 PD (below 3.84 Watt)
- According to IEEE Std. 802.3af

1.2.4 Cables and Wiring

A standard Ethernet cable can be used to connect the WMF weigh module to the control systems.

Specifications

- Weigh module side connector: M12-4 position, D-coded, female
- System side connector: according to Switch (RJ45 or M12)
- Shielded cable (AWG 22)
- Maximum cable length: 100 m

Please refer to the installation guides of the user organizations:

- PROFINET IO RT: <http://www.profibus.com/download/installation-guide>, refer to "Profinet Installation Guide"
- EtherNet/IP: <https://www.odva.org/> refer to "EtherNet IP Media Planning and Installation Manual".

1.2.5 Status LEDs and Reed Switch

Overview

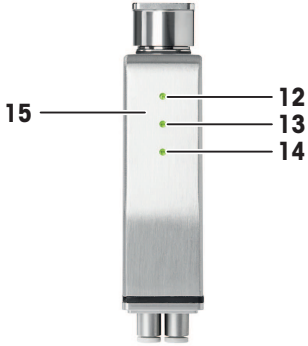
Status LEDs	
	Module status
	12 Status, bicolor green/red
	Industrial Ethernet status
	13 NS / BF, bicolor green/red
	14 MS / SF, bicolor green/red
Reed switch	
15 Reed switch function (between the LED on the top and the one in the middle)	

Module Status LED (12)

The module status LED (12) indicates the diagnostic condition of the weigh module. It can display the following signals:

Status	Meaning	Remedy
Green	Normal operation	–
Red, blinking	Warning: still functional, but close to the limits of the permissible operating tolerances	<ol style="list-style-type: none"> 1 Check the temperature of the electronics and the working condition of the active cooling system. 2 Fix it if necessary.
Red, solid	Error: weight results not valid, check the corresponding error status	– Switch off power (PoE -> off) to prevent any potential damage on the electronics.

MT-SICS Error codes

Code	Meaning
* 10	Non-volatile data memory error (EEPROM)
* 104	PCBA temperature exceeded

Industrial Ethernet status LED NS / BF (13)

EtherNet/IP		
Color	State	Meaning
Green	Solid	Connected: If the device has at least one established connection, the network status indicator shall be steady green.
	Blinking	No connections: If the device has no established connections, but has obtained an IP address, the network status indicator shall be flashing green.
Red	Solid	Duplicate IP: If the device has detected that its IP address is already in use, the network status indicator shall be steady red.
	Blinking	Connection timeout: If one or more of the connections in which this device is the target has timed out, the network status indicator shall be flashing red. This shall be terminated only if all timed out connections are reestablished or if the device is reset.
Red/green	Blinking	Self-test: While the device is performing its power up testing, the network status indicator shall be flashing green/red.
–	Off	No power, no IP address: If the device does not have an IP address or is powered off, the network status indicator shall be steady off.

PROFINET IO RT		
Color	State	Meaning
Red	Solid	No connection: No link No valid Master license
	Blinking cyclic at 2 Hz	Configuration fault: not all configured IO devices are connected
–	Off	No error

Industrial Ethernet status LED MS / SF (14)

EtherNet/IP		
Color	State	Meaning
Green	Solid	Device operational: If the device is operating correctly, the module status indicator shall be steady green.
	Blinking	Standby: If the device has not been configured, the module status indicator shall be flashing green.
Red	Solid	Major fault: If the device has detected a non-recoverable major fault, the module status indicator shall be steady red.
	Blinking	Minor fault: If the device has detected a recoverable minor fault, the module status indicator shall be flashing red. Note: an incorrect or inconsistent configuration would be considered a minor fault.
Red/green	Blinking	Self-test: While the device is performing its power up testing, the module status indicator shall be flashing green/red.
—	Off	No power: If no power is supplied to the device, the module status indicator shall be steady off.

PROFINET IO RT		
Color	State	Meaning
Red	Solid	No valid Master license.
	Blinking cyclic at 2 Hz	System error: Invalid configuration, watchdog error or internal error. Note: an incorrect or inconsistent configuration would be considered a minor fault.
—	Off	No error.

Reed Switch (15)

The reed switch is an electrical contact, activated by a commercial magnet. It is located at position (1).

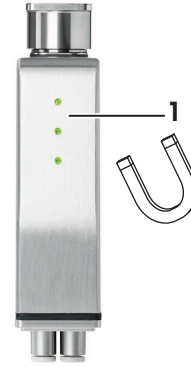

The following functions can be executed by activating and deactivating the reed switch.

Factory reset

To perform a factory reset, the following reed switch pattern has to be applied:

- 1 Activate the reed switch for 5 seconds and release it.
- 2 Wait at least 1 second.
- 3 Activate the reed switch for 5 seconds again and release it.

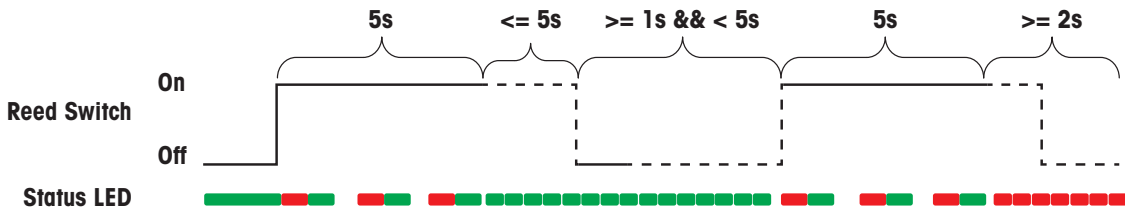

All settings are set back to factory configuration

Temporary reset of IP

To perform a temporary IP reset, the following reed switch pattern has to be applied:

- 1 Activate the reed switch for 5 seconds and release it.
 - 2 Wait at least 5 seconds.
- ⇒ The exact timing is visualized below.

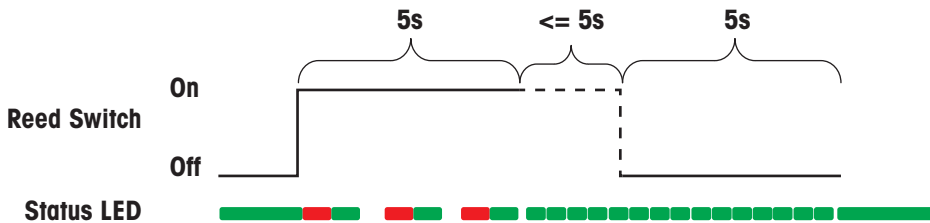

Temporary reset of the network interface to factory settings: IP address 192.168.0.55, Port 80
After a power cycle, the network settings are set back to the configured customer settings.

2 Configuration

There are 2 types of access to configure the WMF weigh modules, either via Ethernet TCP/IP or Industrial Ethernet.

Some parameters like filter settings and stability criteria can be configured in the PLC as module parameters which are sent after each power up to the weigh module automatically. If the same parameters are changed via Ethernet TCP/IP with the PC configuration, they can be automatically overwritten by the PLC after a power cycle.

NOTICE

Risk of malfunction

- 1 Please be aware that the configuration completed through one interface can overwrite the other.
- 2 Make the configuration of all parameters via a single interface, e.g., use only PLC for all configuration purposes.

2.1 Industrial Ethernet

WMF weigh modules use the SAI protocol to communicate with the control system. SAI stands for **Standard Automation Interface** and is defined by METTLER TOLEDO.

SAI is tailored for cyclic and acyclic communication.

For more information refer to the SAI Reference Manual for APW products:

Documentation WMF

► <http://www.mt.com/WMF>

WMF weigh modules can be fully configured by the PLC. The steps required to configure the weigh module by PLC are explained in more detail in the PLC Integration Guide for SAI:

Documentation WMF

► <http://www.mt.com/WMF>

2.2 Ethernet TCP/IP

WMF weigh modules use the MT-SICS protocol to communicate with a PC or laptop. MT-SICS stands for METTLER TOLEDO **Standard Interface Command Set**.

MTSICS is an ASCII-based communication protocol with string-type data format.

For more information refer to the Reference Manual for MT-SICS Interface Commands:

Documentation WMF

► <http://www.mt.com/WMF>

APW-Link™ software from METTLER TOLEDO can be used to configure the weigh module with MT-SICS commands. APW-Link™ can be downloaded from the following link free of charge:

APW-Link Download Link

► <http://www.mt.com/apw-link>

3 Operation

3.1 Operation Limits

When operating WMF weigh modules, the following maximum permissible overload values should not be exceeded:

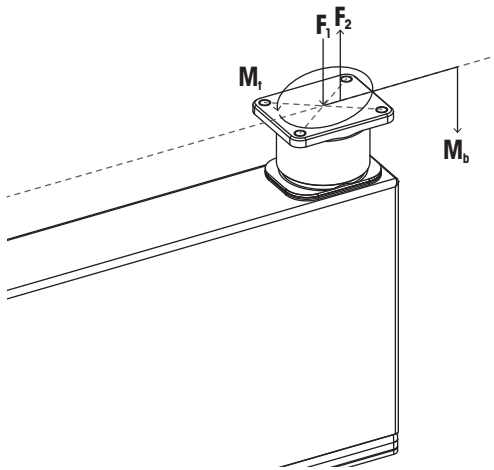

Max. permissible overload in vertical downward direction F_1	30 N
Max. permissible overload in vertical upward direction F_2	10 N
Max. permissible bending moment M_b	0.03 Nm
Max. permissible torsion moment M_t	0.02 Nm

NOTICE

Damage to the weigh module

- Observe the above given maximum permissible overload when installing and using a custom weighing platform.

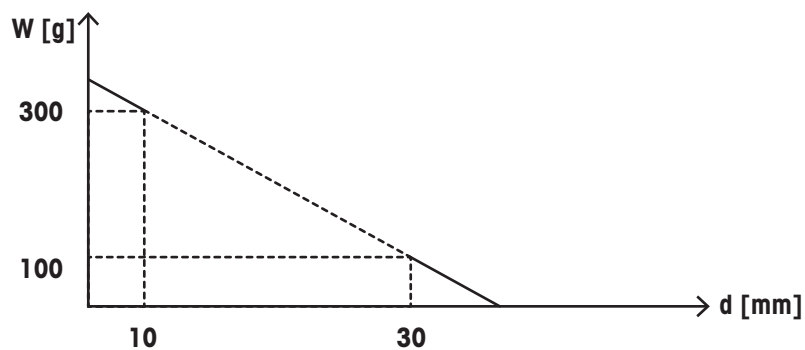

Example for the maximum bending moment of 0.03 Nm:
10 mm / 300 g; 15 mm / 200 g; 30 mm / 100 g

Environmental conditions: Refer to General Data. The specified metrological performance of the weigh module is ensured for the compensated temperature range (10 ... 30 °C).

3.2 Applying / Removing the Weighing Object

When applying or removing the weighing object on / from the weighing platform, observe the following important rules:

- Excessive additional forces or vibrations affecting the weighing platform as a result of applying or removing the weighing object can impair the weighing duration and the result.
- Make sure that you keep additional forces and vibrations to a minimum when applying or removing the weighing object. Lateral impacts should be avoided.
- The weighing object should come to rest on the weighing platform as quickly as possible once it has been applied. If the weighing object is pushed sideways onto the weighing platform by a feed mechanism, a certain height difference between the weighing platform and the loading/unloading arm should be ensured. The weighing pan should be lower than the loading level and higher than the unloading level.
- Make sure that the object or its center of gravity is as close to the center of the weighing platform as possible during weighing or that it is always applied in the same way.
- It is not recommended to move the weigh module toward the weighing object. This kind of setups can cause shock overloads inside the weigh module due to the dynamic movement in a short time. Shock overloads are always difficult for the weigh module to handle and might lead to failure over the long term.

3.3 Air connections

WMF weigh modules have 4 connections for the air supply.

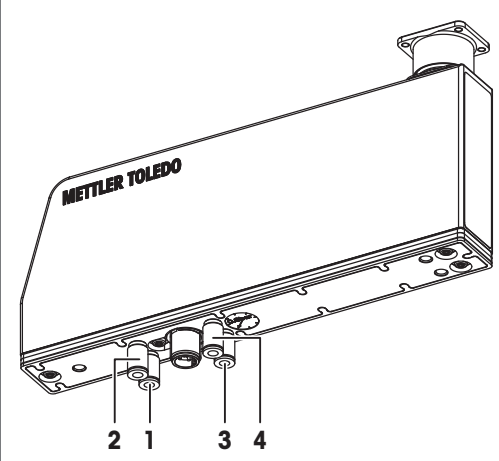
	1	Air inlet for cooling function (can be ordered as an accessory)
	2	Air outlet for cooling function (can be ordered as an accessory)
	3	Air connection for wash-down function (only available with the wash-down version)
	4	Deaeration plug for wash-down function (only available with the wash-down version)

Cooling function

The cooling function must be used if multiple weigh modules are mounted in a tight multi-line arrangement, where the weigh modules are installed next to each other with a distance smaller than 10 mm, which in turn can increase the internal temperature of the weigh modules. To cool down the weigh modules, air can be supplied via the air connector (1).

The air connector (1) should be supplied with a constant air flow of 15 l/min \pm 2 l/min to activate the cooling function. The supplied air is circulated inside the bottom plate to cool down the electronics of the weigh module. The deaeration plug (2) should be left open to transfer the circulating air to the outside.

The air outlet of one weigh module can be connected to the air inlet of another weigh module in a daisy chain fashion. This way, cable material can be saved and installation facilitated.

Wash-down function

The wash-down function can be used if the weigh module is to be cleaned with a water spray. This function should only be activated when the weigh module is not in use (de-energized).

The air connector (3) should be supplied with 0.6 \pm 0.1 bar air pressure and the deaeration plug (4) should be left open to transfer the air to the outside in case there is an air leakage from the wash-down bellow.

Before starting with the wash-down operation, it should be ensured that the wash-down bellow is blown up properly by the air supply, so that it effectively seals the weighing pan from inside. This can be tested by trying to turn the weighing pan. By a proper block, the weighing pan should be locked against any rotation.

In normal operation, the deaeration plug (4) should be closed to prevent any air circulation inside the weigh module.

We recommend to use a 4/2 way valve as the picture shows.

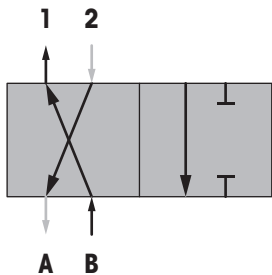
	1	Air connection for wash-down function
	2	Deaeration plug for wash-down function
	A	Deaeration (open during wash-down, closed during normal operation)
	B	0.6 bar (supplied during wash-down, inactive during normal operation)

4 Calibration and Adjustment

As your weigh module is a precision measuring instrument, periodic maintenance is a prerequisite for perfect operation. The maintenance intervals depend on usage, ambient and environmental conditions. Maintenance work may only be performed by a METTLER TOLEDO service technician.

Checking the weighing performance

The precision of the weigh module is normally monitored by the tests function. You can find the necessary commands for calibration and adjustment in the MT-SICS reference manual.

Documentation WMF

► <http://www.mt.com/WMF>

Relevant documentation:

- MT-SICS Interface Command for Weigh Modules
- Overview List MT-SICS for APW

It is recommended, that the linearity, repeatability and other key figures of the weigh module are checked by a METTLER TOLEDO service technician. Contact us about a service agreement tailored to your needs and budget.

APW-Link software can also be used in order to perform calibration and adjustment with the graphical user menu in an easier way. APW-Link software can be downloaded after registration free of charge.

APW-Link Download Link

► <http://www.mt.com/apw-link>

Replacing the seal sets

The seal sets must be checked periodically and replaced after a maximum of 2 years by a METTLER TOLEDO service engineer to ensure that the weigh module is properly protected.

An appropriate seal set is included in the range of spare parts, see Accessories and Spare Parts.

5 Technical Data

5.1 General Data

Power supply	Power over Ethernet (PoE) Mode A (end span) Class 1 PD (below 3.84 Watt) According to IEEE Std 802.3af/at
Electrical connection	Ethernet cable (M12-4 Position, D-Coded)
<ul style="list-style-type: none"> Recommended cable cross-section of the data lines 	0.25 mm ² , 24 AWG
Interfaces	PROFINET IO RT or EtherNet/IP
Air connectors	
<ul style="list-style-type: none"> Air connection 	External hose diameter: 4 mm (5/32") Internal hose diameter: 2.5 mm (1/10")
<ul style="list-style-type: none"> Air pressure for wash-down 	nominal: 0.6 ±0.1 bar (8.7 psi)
<ul style="list-style-type: none"> Air flow for cooling 	15 l/min
IP protection rating	in operational state with weighing pan in place
<ul style="list-style-type: none"> During weighing 	IP44
<ul style="list-style-type: none"> "Wash-down" during cleaning (seal set activated with 0.6 bar air pressure) 	IP65
Typical service life of the seal sets	2 years
Maximum tilt	Deviation from horizontal
<ul style="list-style-type: none"> Longitudinal axis 	0.5 %
<ul style="list-style-type: none"> Lateral axis 	0.5 %
Permissible environmental conditions	WMF weigh modules may only be used in enclosed indoor areas
<ul style="list-style-type: none"> Ambient temperature range 	+5 to +40 °C
<ul style="list-style-type: none"> Height above sea level 	Max. 4000 m
<ul style="list-style-type: none"> Humidity (at 30 °C / 85 °F) 	up to 80 % relative humidity
<ul style="list-style-type: none"> Warm-up time 	at least 45 minutes after connected to power
Materials	
<ul style="list-style-type: none"> Casing, base plate, cover, flange 	Stainless steel (1.4404-316L)
<ul style="list-style-type: none"> Weighing platform 	Stainless steel (1.4404-316L)
<ul style="list-style-type: none"> Seal between flange and upper part of housing 	Silicone, FDA-compliant
<ul style="list-style-type: none"> Seal between lower part of the housing and base plate 	Silicone, FDA-compliant
<ul style="list-style-type: none"> Inflatable bellows in "wash-down" model 	Silicone 40 ShA FDA approved
Surface roughness of the housing	N7 or better

5.2 Type Designation Code

Your weigh module is uniquely identified by the type designation. The type designation can be found on the laser label on your weigh module.

WMF – /

1
2
3
4
5

#	Designation	Values
1	Capacity and resolution	204 : 220 g capacity / 0.1 mg readability 303 : 320 g capacity / 1 mg readability
2	Internal calibration	C: with internal calibration
3	Seal	L: Labyrinth W: "Wash-down"
4	Fieldbus type	IE: EtherNet/IP PN: PROFINET IO RT
5	Customer specific version	00 ... 99

5.3 Interface Specifications



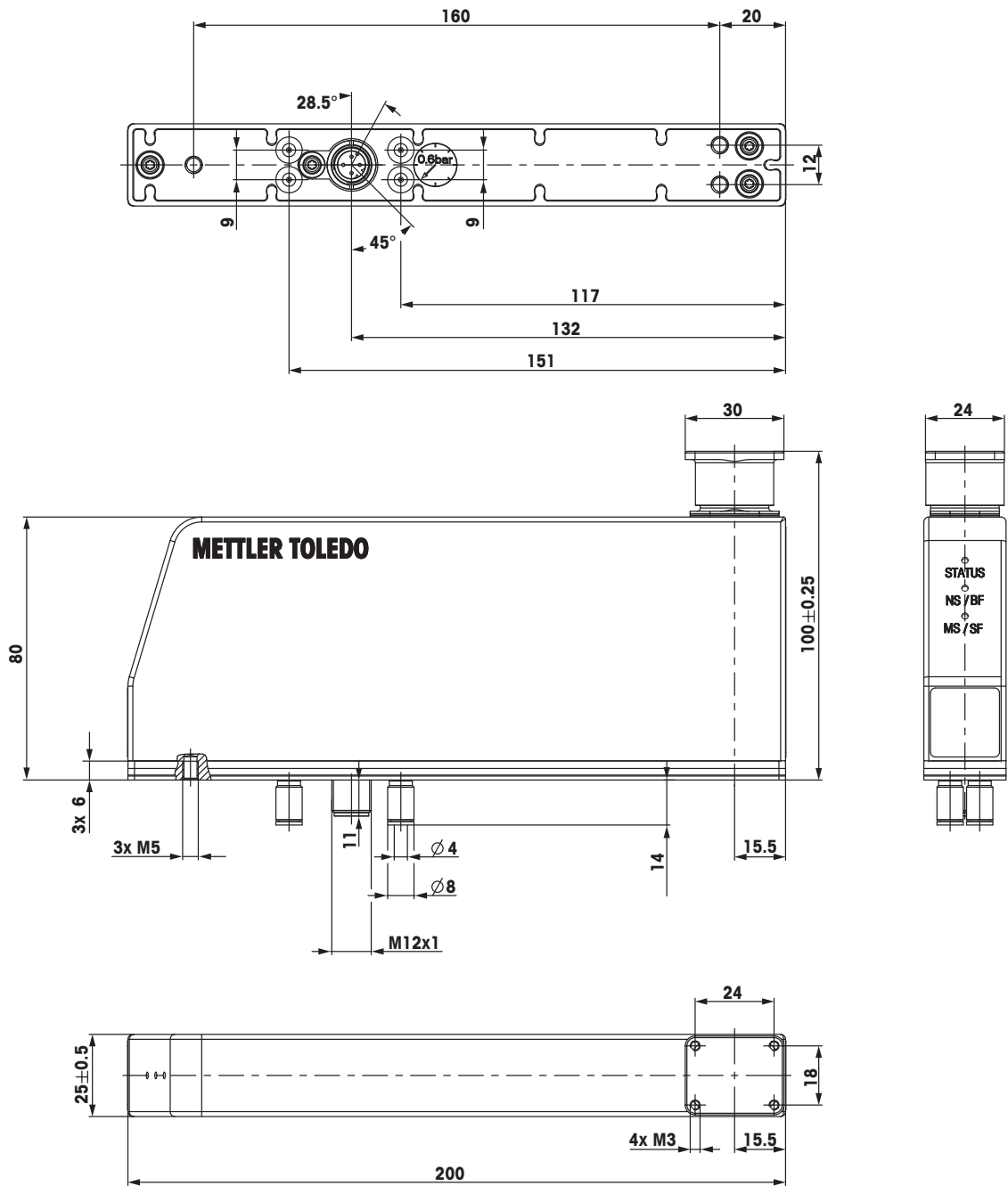

Parameter	PROFINET IO RT	EtherNet/IP
Interface type	PROFINET IO RT – Device RT_CLASS_1 Conformance Class CC-B	EtherNet/IP Adapter
Max. cable length	100 m	
Max. number of nodes / segments	Limited by the IP address	
Type of operation	full duplex	
Type of transmission	asynchronous, synchronous	
Baud rates	100 Mbit/s	10 ... 100 Mbit/s
Default IP address	192.168.0.55	
Port number	80	
DHCP	Not available	On
Vendor ID	0 x 29B	0 x 29A

5.4 Dimensions

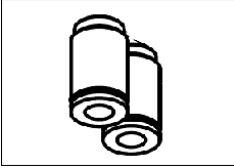

6 Accessories and Spare Parts

6.1 Accessories

	Description	Part No.
	Air connector WMF (for cooling function)	30 307 194
	Weighing platform without threaded holes	30 300 173
	PoE injector to supply power to the weigh module	30 326 111
	Ethernet/USB converter to connect to a service PC or laptop	30 326 110
	Connection cable for the weigh module, M12-RJ45 2 m 5 m 10 m	30 326 112 30 401 900 30 401 920

6.2 Spare Parts

Picture	Description	Part number
	<p>Sealing Set</p> <p>1 Gasket flange 2 Gasket cooling 3 Gasket housing 4 O-ring, 5 pcs. 5 Gasket bottom</p>	<p>30 307 192</p>
	<p>Wash-Down Set</p> <p>1 Wash-down unit 2 Gasket flange</p>	<p>30 307 193</p>
	<p>Gasket bottom WMF</p>	<p>30 307 195</p>
	<p>Weighing platform with threaded holes</p>	<p>30 332 418</p>

GWP®

Good Weighing Practice™

GWP® is the global weighing standard, ensuring consistent accuracy of weighing processes, applicable to all equipment from any manufacturer. It helps to:

- Choose the appropriate balance or scale
- Calibrate and operate your weighing equipment with security
- Comply with quality and compliance standards in laboratory and manufacturing

 www.mt.com/GWP

www.mt.com

For more information

Mettler-Toledo GmbH

Industrial
8606 Nänikon, Switzerland
www.mt.com

Subject to technical changes.
© Mettler-Toledo GmbH 02/2018
30275981G en



30275981