

## Optimize Space Increase Sales

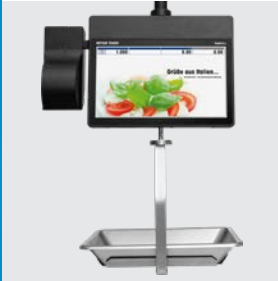

### Sales-Boosting Design

The FreshWay H enables in-store marketing with high power reserves that support graphics-intensive digital signage campaigns at the POS. The bright 15.6" customer display can increase your bottom line with sales-boosting promotions.



### Ergonomic Operation

The large display and simple, responsive operation of the FreshWay H make the scale both ergonomic and easy to use for employees. This ensures fast, error-free weighing and operating processes, even at peak times.



### Durable Housing

Impact-resistant aluminum housing with a non-stick surface protects the FreshWay H scale against spills, acids, salts, and fats. This makes it ideal for long-term usage, even in highly-demanding retail conditions.



### Wide Range of Printer Units

The FreshWay H hanging scale is available with various printer units for tickets and labels. The optional 2" label printer is ideal for printing certificates of origin and practical preparation tips.



### FreshWay H

#### Next generation PC hanging scale

The PC-based FreshWay H hanging scale allows retailers to maximize counter space while effectively promoting products to customers. FreshWay H combines the advantages of a space-saving hanging scale with the benefits of a large 15.6" customer display screen that can be leveraged to boost sales.

The robust, high-performance design of the FreshWay H ensures future-proof, state-of-the-art weighing technology for even the most demanding retail environments. The ergonomic design benefits service staff with easy and convenient operation, helping simplify and optimize customer interactions.

# Technical Data

## FreshWay H

### Operator Display

- 15.6-inch (39.6 cm) capacitive TFT-touchscreen with bright, high-contrast LED backlight technology
  - Screen resolution: 1.366 x 786 pixels

### Customer Display

- 15.6-inch (39.6 cm) customer display with bright, high-contrast LED backlight technology
  - Screen resolution: 1.366 x 786 pixels

### Printer

- Printing width: 56 mm
- Paper width: 44 – 62 mm
- Printing speed: up to 150 mm/sec.
- Print resolution: 8 dots/mm
- Separate paper feed button
- 2-inch ticket printer
  - Roll diameter: 70 mm
  - Automatic paper cutter
- 2-inch linerless printer
  - Roll diameter: 120 mm
  - Automatic paper cutter
- 2-inch label printer
  - Roll diameter: 120 mm

### Processor

- Intel® processor

### Data Storage

- LPDDR4 RAM (Low Power Double Data Rate RAM)

### Operating System

- Microsoft Windows®

### Scale Software

- UC3 application
- Driver software for VCO third-party applications

### Housing

- Impact-resistant housing made of die-cast aluminum
- Housing surface with non-stick coating
- Color: Black

Weighing range	6 kg / 15 kg
Graduation	2 g / 5 g
Minimum load	40 g

Intel is a registered trademark of Intel Corporation in the U.S. and/or other countries. Microsoft® and Windows® are registered trademarks of Microsoft Corporation in the United States and/or other countries.

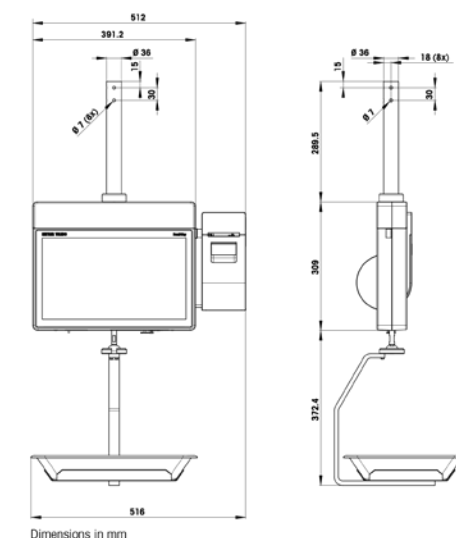
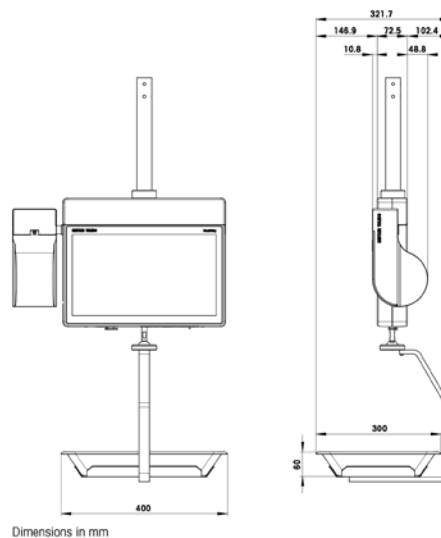

[www.mt.com](http://www.mt.com)

For more information

**METTLER TOLEDO Group**

Retail Division

Local contact: [www.mt.com/contacts](http://www.mt.com/contacts)

Subject to technical changes

©07/2021 METTLER TOLEDO. All rights reserved

Document No. 30536839 A

MarCom Industrial

